

# Grid Interface Control and Simulation of PMSG Wind Energy Conversion System Based on NPC Multilevel Inverter

Md. Inayat Ali

Department of Electrical Engineering  
Faculty of Engineering & Technology  
MACET Patna- 801113  
Inayat2k9bit@gmail.com

Intesar Hasan

Department of Electrical Engineering  
Faculty of Engineering & Technology  
MACET Patna-801113  
hasanintesar@yahoo.com

Aaisha Tasneem

Department of Electrical Engineering  
Faculty of Engineering and Technology  
MACET Patna 801113  
aaisha.tasneem@gmail.com

Amit Kumar

Department of Computer Science & Engineering  
Faculty of Engineering & Technology  
MACET Patna 801113  
amitk.macet@gmail.com

**Abstract**— This multilevel inverter for the grid interface of permanent magnet synchronous generator. Currently, DFIG based variable speed wind turbine technology with gearbox is dominating the world market share. However, the problems associated with IG based wind turbines paper presents a wind energy conversion system based on a neutral-point clamped are reactive power consumption, mechanical stress and poor power quality. Moreover, the gearbox requires regular maintenance as it suffers from faults and malfunctions. PMSG based wind turbines are; gearless operation, higher efficiency, enhanced reliability, smaller size, reduced cost and low losses. The NPCMLI has been used as a VSI and operated in a voltage control mode in order to achieve the objectives of real power injection and load compensation (power factor correction, load balancing, voltage fluctuation elimination and harmonic compensation). This paper focuses on control of PMSG based grid connected variable speed WT with maximum power extraction (MPE). Simulation of the proposed model has been done in MATLAB/SIMULINK and from the results obtained through simulation are shown.

**Keywords**— *Permanent Magnet Synchronous Generator (PMSG); Variable Speed Wind Turbine; Wind Power; Wind Energy Conversion System.*

## I. INTRODUCTION

Wind energy has proved to be the most promising renewable energy source because of its environment friendliness, sufficient availability, and good conversion efficiency. The current trend in wind turbines is to increase the size of the turbine in order to harvest more energy and thus reduce cost per megawatt of capacity. Power ratings of 3–5 MW per machine are becoming common in areas with large wind potentials, especially offshore wind installation. The major problem in interfacing such machines to the grid is the limitation imposed by the ratings of currently available switching devices in the converter. The ratings of the semiconductor devices used in the conventional two-level or three-level VSI topologies do not support the higher power ratings necessary for the grid interface of such large machines. This has motivated designers to go for medium-voltage converters as these are more compact than low-voltage converters for power larger than 1.5 MW. The use of multilevel VSI topology for distributing voltage stress and power losses

between a number of devices has been well reported and the multilevel inverters are suitable for modern high-power wind-turbine applications. main concept of this inverter is to use diodes, a diode transfers a limited amount of voltage there by reducing the stress on other electrical device. wind turbines have been operated only as energy sources and have not been expected to provide grid support functions like voltage support, frequency control, fault ride through, and spinning reserve, but as the penetration of wind in the overall generation mix increases, new grid codes have been constituted, which stipulate that wind farms must provide some of these functionalities. Recently, it has been suggested that wind farms may be used to provide reactive power support to the grid as a part of the ancillary service provisions

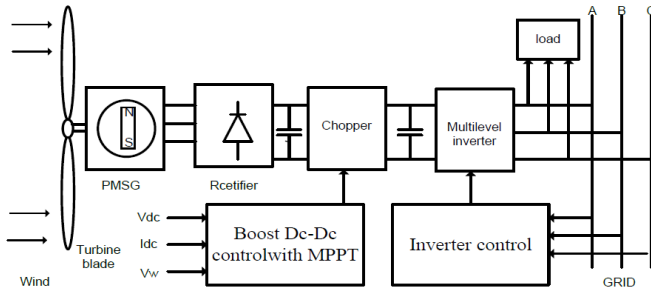

Fig 1. Wind Power Generation System

This paper deals with the performance analysis of PMSG based Wind Power Generation System in standalone mode. The Performance of a WPGS consisting of PMSG, battery, fuel cell and Power Electronic Converters is analyzed in this paper by developing a model in MATLAB Simulink.

II. PROPOSED WIND POWER GENERATION SYSTEM

Fig. 1 shows the system structure of a PMSG based variable speed wind turbine using switch mode rectifier. The system consists of Diode rectifier, Dc-Dc Boost Converter, Dc link Capacitor, Multilevel inverter with controller, Grid and local load. As the wind speed changes, the output of the generator varies in amplitude and frequency. The function of the power electronic interface and associated controllers is to produce an output with regulated voltage and frequency to supply power to the grid or local load. The diode rectifier converts the variable output AC voltage to DC voltage and the boost DC to DC converter the rectifier output DC voltage to a higher regulated DC voltage level suitable for the inverter operation. The output of the switch-mode rectifier can be controlled by controlling the duty cycle of the IGBT (insulated gate bipolar transistor) switch at any wind speed to extract maximum power from the wind turbine. The boost DC-DC converter should be designed properly so that the DC link voltage at the inverter input is maintained to a fixed level over the entire operating range of the generator for wind speeds between cut-in speed and rated speed. This will ensure the delivery of maximum captured power to the grid or local load. The vector controlled IGBT inverter is used to interface wind energy system to local load and grid.

III. WIND POWER PARAMETERS

1. Power in wind

Wind energy is the K.E of air in motion or wind. Wind energy is an indirect form of solar energy which can be used continuously. unlike solar energy. wind energy is free, renewable resource so no matter how much is used today, there will be still be the same supply in the future. wind energy is also a source of clean nonpolluting electricity, no air pollutants or no greenhouse gases, no fuel purchases required. Total energy flowing through an imaginary surface with area A during the time t is

$$E = 1/2 MV^2 = 1/2 (AS\rho)V^2$$

$$E = 1/2 At\rho V^3 \tag{1}$$

V=wind velocity  
A\*V\*t=volume of air passing through A  
 $\rho$ =density of air (1.225 kg/m<sup>3</sup>, at 150 C and 1 atm.)  
A = cross-sectional area through which the wind passes (m<sup>2</sup>)  
So wind power is  $P = E_t = 1/2 A\rho V^3$   
A below plot show. The power in the wind increases as the “cube” of the wind speed.

2. Power Extracted from Wind

As wind is not a constant source of energy due to its continuous variation over a period of time and it provides energy in an unexpected manner. Almost half of the total energy is generally given out in about 10-15% of the operating time. As wind speed varies one cannot depend on wind for continuous power. Rather it can be used with a system having considerable reserve capacity like hydro and/or reserve load such as dump load like electrolyzer. The power extracted from the wind can be calculated by (2).

$$P_m = 0.5\rho AC_p (\lambda, \beta)V_{wind} \tag{2}$$

Where,

- $P_m$  = Extracted power from the wind
- $V_{wind}$  = Velocity of wind in m/sec
- A = Total area swept by blade;  $\rho$  = Density of air
- $C_p$  = The power coefficient [which is a function of both tip speed ratio ( $\lambda$ ), and blade pitch angle ( $\beta$ ) (deg.)]

3. Power Coefficient ( $C_p$ )

The kinetic energy of wind is converted into mechanical energy with the help of wind blades which in turn drive the shaft of wind generator.

The power coefficient  $C_p$  use for converting efficiency in first stage is given by (3).

$$C_p = \frac{P_{out}}{P_w} = \frac{P_{out}}{(1/2)\rho A(V_{wind})^3} \tag{3}$$

Where,

- $P_{out}$  – Extracted Power from wind
- $P_w$  – Available wind power,  $\rho$  – Density of air
- A – Total area swept by blade;  $V_{wind}$  – Wind speed in m/sec

IV. DC LINK VOLTAGE CONTROL

The output of the three phase rectifier is fed to the input of the boost DC-DC converter to step up the DC link voltage ( $V_{dc2}$ ) to a suitable level for the proper operation of the inverter. Fig.4.4 show the boost dc to dc converter. The boost DC-DC converter is designed in such a way that the DC link voltage which is the input to the inverter is regulated under different wind speeds. The boost dc-dc converter is controlled to extract maximum power under varying wind speed as shown in Fig.2 The output of the boost DC-DC converter is given by

$$V_{dc2} = V_{dc1} / (1 - D) \tag{4}$$

Where  $V_{dc1}$  = input voltage of Dc-Dc chopper (V),  $V_{dc2}$  = output voltage of Dc-Dc boost converter(v),  $D$  = Duty cycle

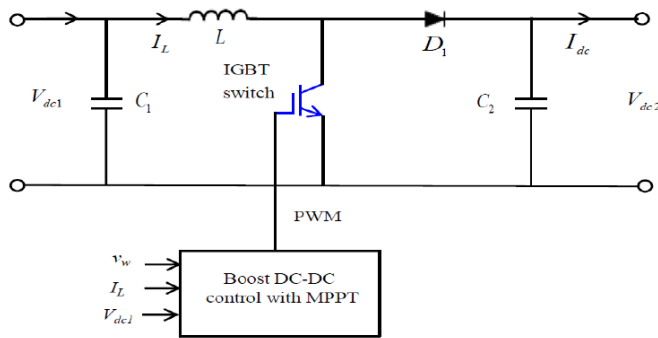

Fig 2 Dc- Dc Boost Converter

To extract optimum power under fluctuating wind speeds, the speed of the generator needs to be regulated by controlling the IGBT switch of the boost DC-DC converter. By regulating the wind turbine rotor speed (or generator speed) optimally, the tip speed ratio ( $\lambda$ ) of the turbine can be controlled at the optimum value to obtain maximum  $CP$  under variable wind speed. The optimal wind turbine rotor speed (or generator speed) is proportional to the wind speed. Therefore, the maximum mechanical power is captured by the wind turbine by regulating the generator speed under different wind speeds. Fig 3 shows the proposed algorithm for maximum power extraction (MPE) from the variable speed wind turbine

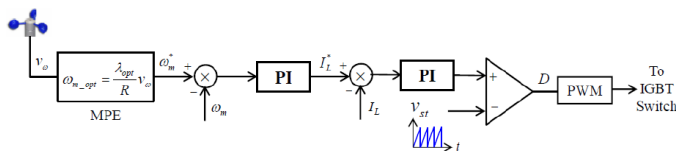

Fig 3 Maximum Power Extraction Algorithm

V. MULTILEVEL INVERTER

Conventional inverters, early in used, was suffering from problems such as higher THD in output Voltage, more switching stress on devices, high switching losses etc. The inverter will also not applicable for high voltage application or high rate of voltage changes. Here multilevel inverter is used as, they are able to generate high output voltages with very low distortion and lower dv/dt. Also bring in input current with very

low input distortion. Well suited for reactive power compensation. And can be functioned with a much lower switching frequency, less Switching stress. And Can be applied for high voltage applications.

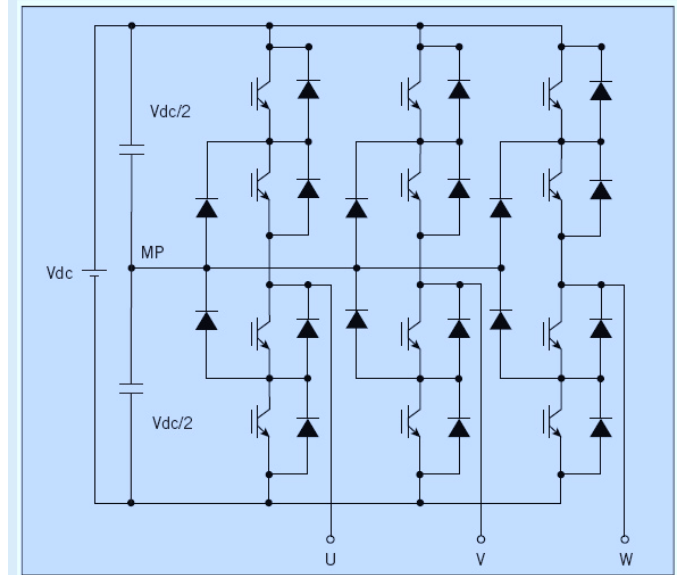

Fig 3 Multilevel Inverter

VI. SIMULATION RESULTS

Simulation result of proposed model are here

1. Figure - 'a' shows the variation of wind speed with time, at the time of starting wind speed is 12 m/s but after 3 secs the speed is reduced to 7 m/s and again at 6 sec speed is 12 m/s.
2. Figure - 'b' shows the generator side voltage whose magnitude is also fluctuating with the wind speed.
3. Figure - 'c' shows the cross ponding variation of active power generated with time due to change in wind speed.
4. Figure - 'd' shows the generator side current it also fluctuates with wind speed
5. Figure - 'e' shows the frequency of generator voltage which is fluctuating between 48 to 62 Hz
6. Figure - 'f' shows the generator side frequency after controlling the PMSG. And after controlling the frequency is close to 50 Hz
7. Figure - 'g' shows the line voltage of multilevel inverter which close to sinusoidal
8. Figure - 'h' shows the generator side voltage and current after controlling

9. Figure - 'i' shows the load side voltage and current after controlling.

Time in (second)  
**Fig- 'a'**  
Time in (second)  
**Fig- 'b'**  
Time in(second)  
**Fig-'C'**

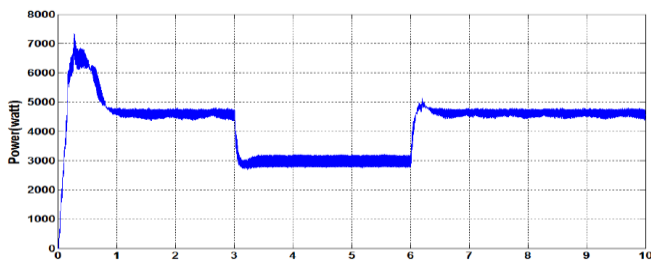
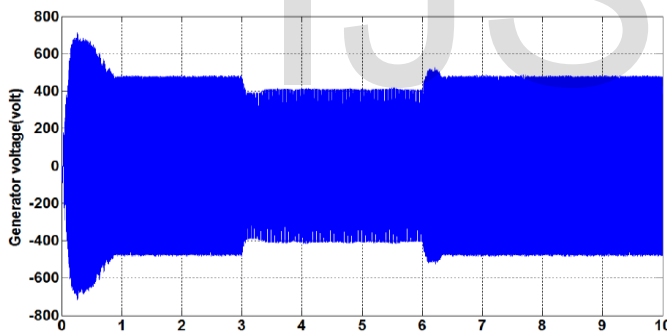
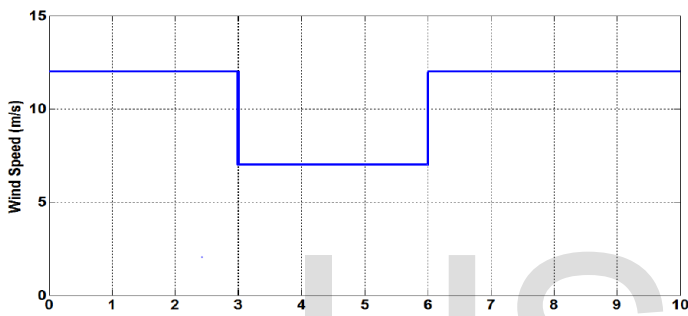
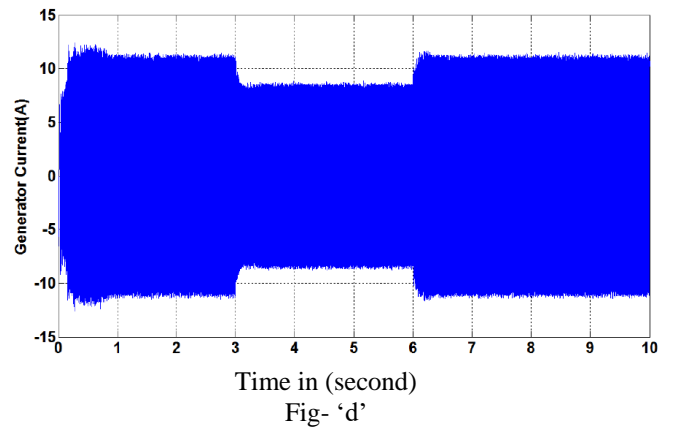

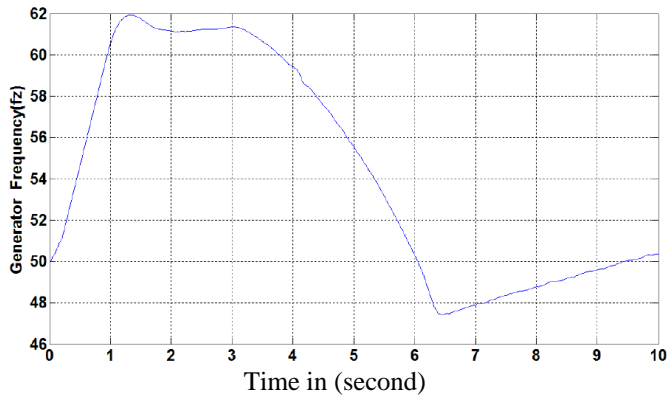

Fig- 'e'

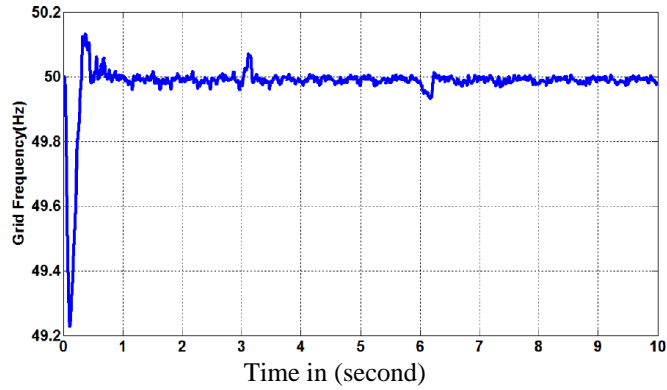

Fig- 'f'

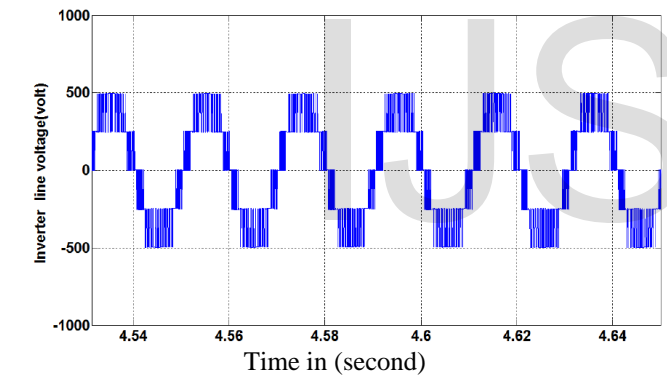

Fig -'g'

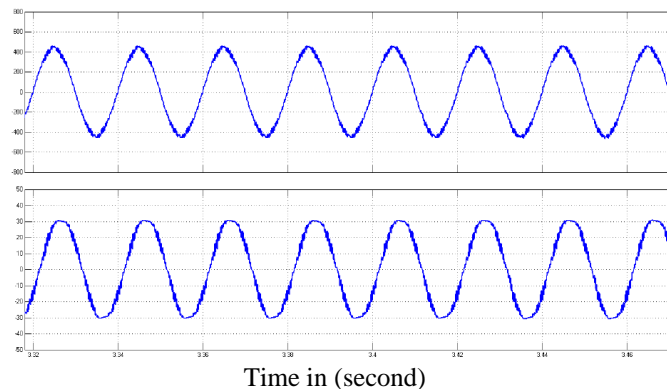

Fig- 'h'

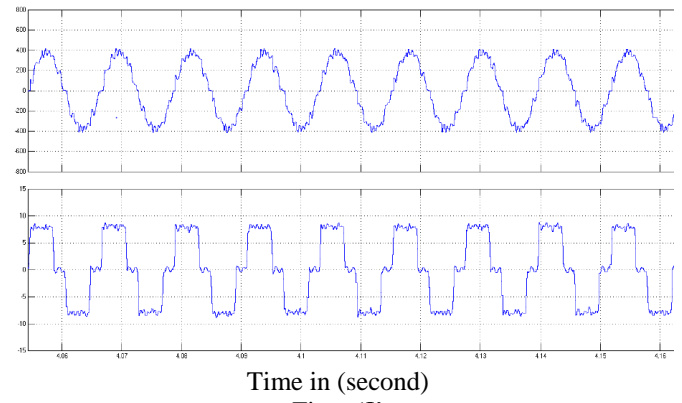

Fig-g 'I'

VII. CONCLUSION

In this paper generated electrical power is supplied to the load and also load extract power from grid to meet the demand. As electrical power generated by wind turbine have variable frequency that's why 1st Ac power is converted into Dc power and then again it converted into Ac power of constant frequency of 50 Hz. Using Three-level NPC Converter, the whole system decreasing output harmonic effectively while improving power capacity of whole equipment, and reducing the voltage stress of switch and the equivalent switching frequency. Simulations show that generator-side can realize the maximum wind power tracking, and makes the generator operate stably and efficiently. The grid-side converter adopts the vector control of grid voltage orientation, which balanced the dc bus voltage and feed-in grid high quality electrical energy.

APPENDIX I

**Wind Turbine System Parameter**

Rated Wind Speed	12 m/s
Nominal Mechanical Output Power	8500 W
Base Power of Electrical Generator	85000/0.9 VA
Base Rotational speed in pu	1
Pitch Angle	0

APPENDIX II

**PMSG Parameters**

Number of poles pairs	5
Rated Speed	125 rad/s
Armature Resistance ( $R_s$ )	0.006Ω
Magnetic Flux Linkage	0.433 Wb
Stator Inductance ( $L_s$ )	8.4 mH
Rated Torque	30 Nm
Rated voltage Phase to Phase	350 V

APPENDIX III

**Simulation parameter of three level inverter**

Switching frequency	3000 Hz
Filter inductance	2 mH
Filter Capacitance	5 micro Farad
Chopper Coil	2 mH
Vol Balancing Capacitance	500 micro farad

REFERENCES

1. M Chinchilla, S. Arnaltes, and J. C. Burgos, "Control of Permanent-Magnet Generators Applied to Variable-Speed Wind-Energy Systems Connected to the Grid" *IEEE Transaction on Energy Conversion*, vol. 21, no 1, pp. 130-135, March 2006
2. B. Wu, Y. Lang, N. Zargari and S. Kouro "Power Conversion and Control of Wind Energy Systems", John Wiley and Sons, 2011.
3. J. Rodríguez, S. Bernet, B. Wu, J. O. Pontt, and S. Kouro. "Multilevel voltagesource- converter topologies for industrial medium-voltage drives," *IEEE Transactions on Industrial Electronics*, vol. 54, no. 6, pp. 2930-2945, 2007.
4. Behera,R.K. ,Wenzhong Gao , Ojo, O. Simulation Study of Permanent Magnet Synchronous Machine Direct Drive Wind Power Generator Using Three Level NPC Converter System. *Power Electronics and Machines in Wind Applications*, 2009. PEMWA 2009. IEEE, pp. 1 – 7.
5. Nabae, I. Takahashi, and H. Akagi, "A new neutral-point-clamped PWM inverter," *IEEE Trans. Ind. Appl.*, vol. IA-17, no. 5, pp. 518–523, 1981.
6. T. Brückner, S. Bernet, and H. Güldner, "The active NPC converter and its loss balancing control," *IEEE Trans. Ind. Electron.*, vol. 52, no. 3, pp. 855–868, Jun. 2005.
7. Akie Uehara, Alok Pratap, Tomonori Goya A Coordinated Control Method to Smooth Wind Power Fluctuations of a PMSG-Based WECS[J]. *IEEE Transactions on Energy Conversion*, Vol.26, No.2, 2011, pp.550-558
8. Omid Alizadeh, student member,IEEE and Amirnasir Yazdani senior member IEEE "a strategy for real power control in a direct drive PMSG based wind energy conversion system" vol 28 no 3rd july 2013
9. Changjin liu Dehong senior member IEEE Nan Zhu Frede balaji "dc voltage fluctuation elimination through a dc capacitor current control for DFIG converter under unbalance grid voltage condition" vol 28 no 7th july 2013
10. W. A. Hill and C. D. Harbourt, Performance of Medium Voltage Multilevel Inverters,IEEE Industry Applications Society (IAS) Conference, Vol. 2, pp. 1186–1192, 1999

IJSER